

仕様 SPECIFICATIONS	
彫削精度 INDEXING ACCURACY	30 sec以内
再現精度 REPEATABILITY	4 sec以内
テーブル最高回転速度 MAXIMUM ROTATION SPEED	33.3 min ⁻¹ [Motor 3000 min ⁻¹]
クランプトルク CLAMPING TORQUE	176N・m [圧力制限値 0.5MPa]
許容最大空圧力 MAXIMUM PNEUMATIC PRESS	0.7 MPa
許容積載質量 横置時 ALLOWABLE MASS OF WORK (HORIZ)	160 kg
許容積載ワーク径 ALLOWABLE WORK DIA.	φ165 mm
総減速比 TOTAL REDUCTION RATIO	1/90
製品質量 MASS OF ROTARY TABLE	100 kg
駆動系モーメント慣性 (モータシャフト) MACHINE INERTIA (DEDUCTED TO MOTOR SHAFT)	0.000134kg・cm ²

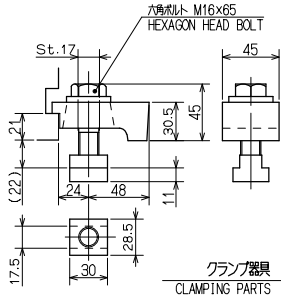

クランプ器具 付属品 4組
 CLAMPING PARTS ACCESSORY 4 PAIR

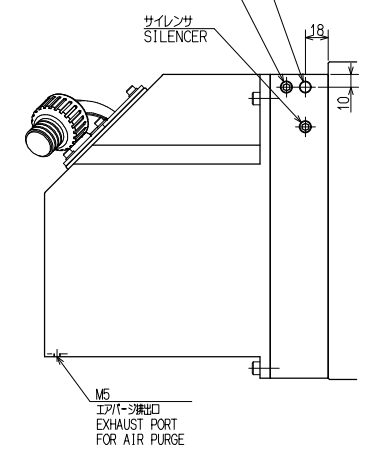
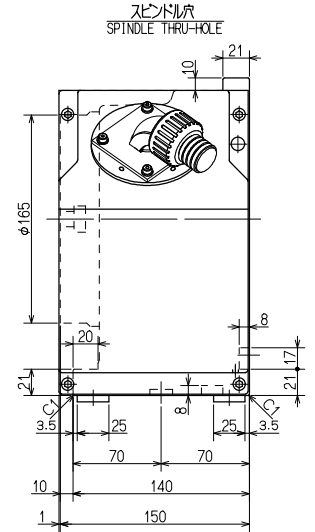
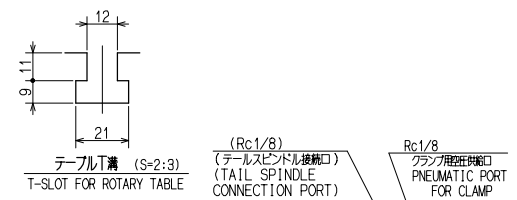
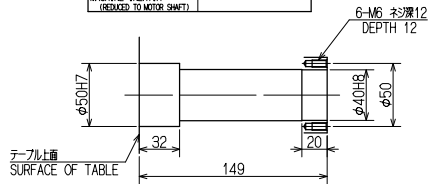
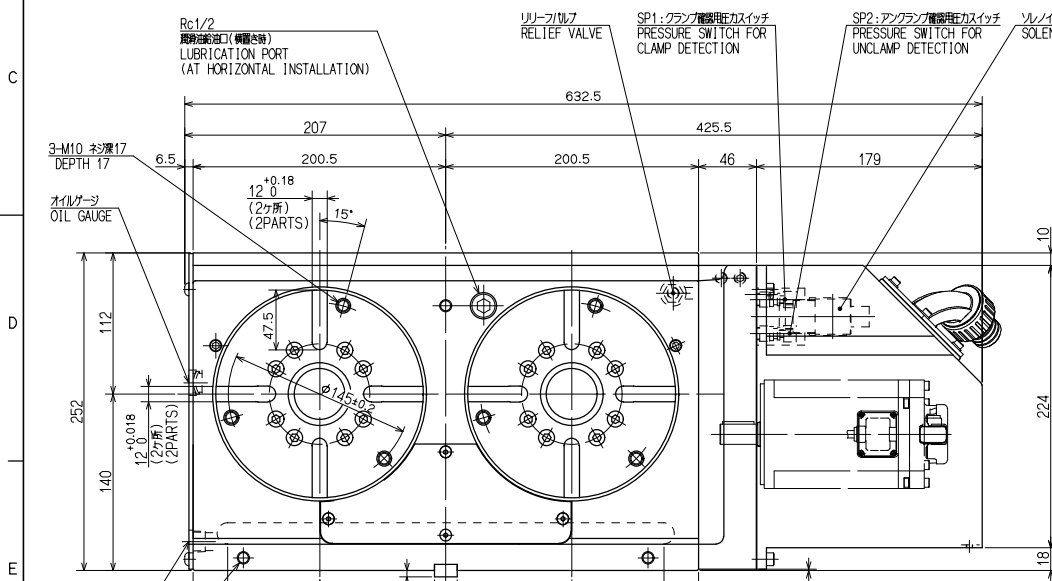
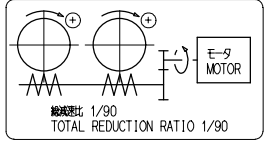

駆動系スケルトン
 SKELTON DRAWING
 OF DRIVE SYSTEM

CAREER			SCALE	TYPE	TM2160AV00	WEIGHT	kg
W.D.			1:3	NCテーブル NC ROTARY TABLE			
MANAGER	CHIEF	DRAWN BY	NAME	TM2160AV00 ガイケイ OUTSIDE VIEW			
KITAGAWA IRON WORKS CO.,LTD.		DATE	DRW NO.	61E282753			